

SHARP SERVICE MANUAL

CODE : 00ZAR5320/A1E

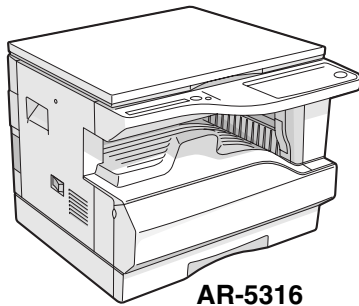

AR-5316

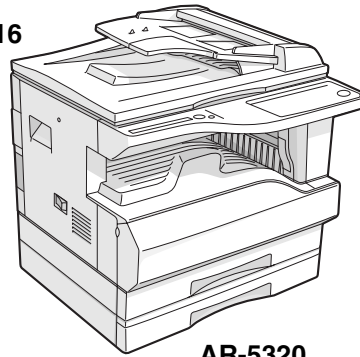

AR-5320
(with option installed)

DIGITAL COPIER

MODEL **AR-5316**
AR-5320

CONTENTS

[1] NOTE FOR THIS SERVICE MANUAL	Refer to AR-M160
[2] SPECIFICATIONS	AR-5316/5320
[3] CONSUMABLE PARTS	AR-5316/5320
[4] EXTERNAL VIEWS AND INTERNAL STRUCTURES	AR-5316/5320
[5] UNPACKING AND INSTALLATION	AR-5316/5320
[6] ADJUSTMENTS	Refer to AR-M160
[7] SIMULATIONS	AR-5316/5320
[8] USER PROGRAMS	AR-5316/5320
[9] TROUBLE CODE LIST	Refer to AR-M160
[10] MAINTENANCE	AR-5316/5320
[11] DISASSEMBLY AND ASSEMBLY	Refer to AR-M160
[12] FLASH ROM VERSION UP PROCEDURE	Refer to AR-M160
[13] ELECTRICAL SECTION	AR-5316/5320

Parts marked with “” are important for maintaining the safety of the set.

Be sure to replace these parts with specified ones for maintaining the safety and performance of the set.

[1] NOTE FOR THIS SERVICE MANUAL

This Service Manual describes only the items related to the AR-5316 and AR-5320. For the other items common with the AR-M160/M205, please refer to the AR-M160/205 Service Manual (Document code:00ZARM205/A1E). The table below shows which document(s) should be referred to for each section. (Refer to the document marked with O.)

Section	AR-M160/M205	AR-5316/AR-5320	Changed item
[1] GENERAL	O		
[2] SPECIFICATIONS	O	O	Some specifications
[3] CONSUMABLE PARTS		O	
[4] EXTERNAL VIEWS AND INTERNAL STRUCTURES	O	O	Appearance / Internal / Operation panel
[5] UNPACKING AND INSTALLATION	O	O	Changing the copy paper size in the tray
[6] ADJUSTMENTS	O		
[7] SIMULATIONS	O	O	Shifter sensors status display, etc. deleted.
[8] USER PROGRAMS	O	O	USB2.0 mode switch, etc. deleted.
[9] TROUBLE CODE LIST	O		
[10] MAINTENANCE		O	
[11] DISASSEMBLY AND ASSEMBLY	O		
[12] FLASH ROM VERSION UP PROCEDURE	O		
[13] ELECTRICAL SECTION	O	O	Block diagram / Actual wiring diagram 1/7

[2] SPECIFICATIONS

The table below shows the specifications of this model and the contents of changes from the AR-M160/M205 and AR-5316/5320.

Item	AR-M160	AR-5316	AR-M205	AR-5320
Paper feed system	1cassette + Multi manual paper feed	One automatic feeding paper tray(250sheets) + bypass tray(100sheets)	2cassette + Multi manual paper feed	Two automatic feeding paper trays(250sheets each) + bypass tray(100sheets)
Weight	Approx.31.3Kg	Approx.31.3Kg (Not including TD cartridge)	Approx.35.1Kg	Approx.36.3Kg (Not including TD cartridge)
Interface	USB1.1/USB2.0 IEEE1284	IEEE1284parallel connector/ USB1.1	USB1.1/USB2.0 IEEE1284	IEEE1284parallel connector/ USB1.1

Option

Machine	Model	AR-M160	AR-M205	AR-5316	AR-5320	Remark
250 sheets paper feed unit	AR-D24 / D25	O	O	-	-	
SPF	AR-SP6	O	-	O	O	
RSPF	AR-RP6	-	O	-	-	
Original cover	AR-VR5	Standard	O	Standard	Standard	

O : The option can be installed.

- : The option cannot be installed.

[3] CONSUMABLE PARTS

1. Supply system table

A. East Europe / Russia

NO	Name	Content	Life	Product name	Remark
1	Toner cartridge(Black) <With IC>	Toner x10 (Toner: Net Weight 537g) Vinyl bag x10	160K	AR-016LT	Life setting by A4 6% document LT=T*10
2	Developer	Developer x10 (Developer : Net Weight 400g)	500K	AR-202LD	LD=DV*10
3	Drum kit	Drum x1 Drum fixing plate x1	50K	AR-202DM	

Note 1: The individual carton is printed with English, German, French, and Spanish as well as the green mark.

B. Middle East / Africa / Philippine

NO	Name	Content	Life	Product name	Remark
1	Toner cartridge(Black) <With IC>	Toner x10 (Toner: Net Weight 537g) Vinyl bag x10	190K	AR-016ET	Life setting by A4 6% document ET=FT*10
2	Developer	Developer x10 (Developer : Net Weight 400g)	500K	AR-202CD	CD=SD*10
3	Drum kit	Drum x1 Drum fixing plate x1	50K	AR-202DR	

Note 1: The individual carton is printed with English, German, French, and Spanish as well as the green mark.

C. Asia

NO	Name	Content	Life	Product name	Remark
1	Toner cartridge(Black) <With IC>	Toner x10 (Toner: Net Weight 537g) Vinyl bag x10	190K	AR-016CT	Life setting by A4 6% document CT=ST*10
2	Developer	Developer x10 (Developer : Net Weight 400g)	500K	AR-202CD	CD=SD*10
3	Drum kit	Drum x1 Drum fixing plate x1	50K	AR-202DR	

Note 1: The individual carton is printed with English, German, French, and Spanish as well as the green mark.

D. Hong Kong

NO	Name	Content	Life	Product name	Remark
1	Toner cartridge(Black) <With IC>	Toner x10 (Toner: Net Weight 537g) Vinyl bag x10	190K	AR-016CT-C	Life setting by A4 6% document CT-C=ST-C*10
2	Developer	Developer x10 (Developer : Net Weight 400g)	500K	AR-202CD-C	CD-C=SD-C*10
3	Drum kit	Drum x1 Drum fixing plate x1	50K	AR-202DR-C	

Note 1: The individual carton is printed with English and Chinese as well as the green mark.

[4] EXTERNAL VIEWS AND INTERNAL STRUCTURES

1. Appearance

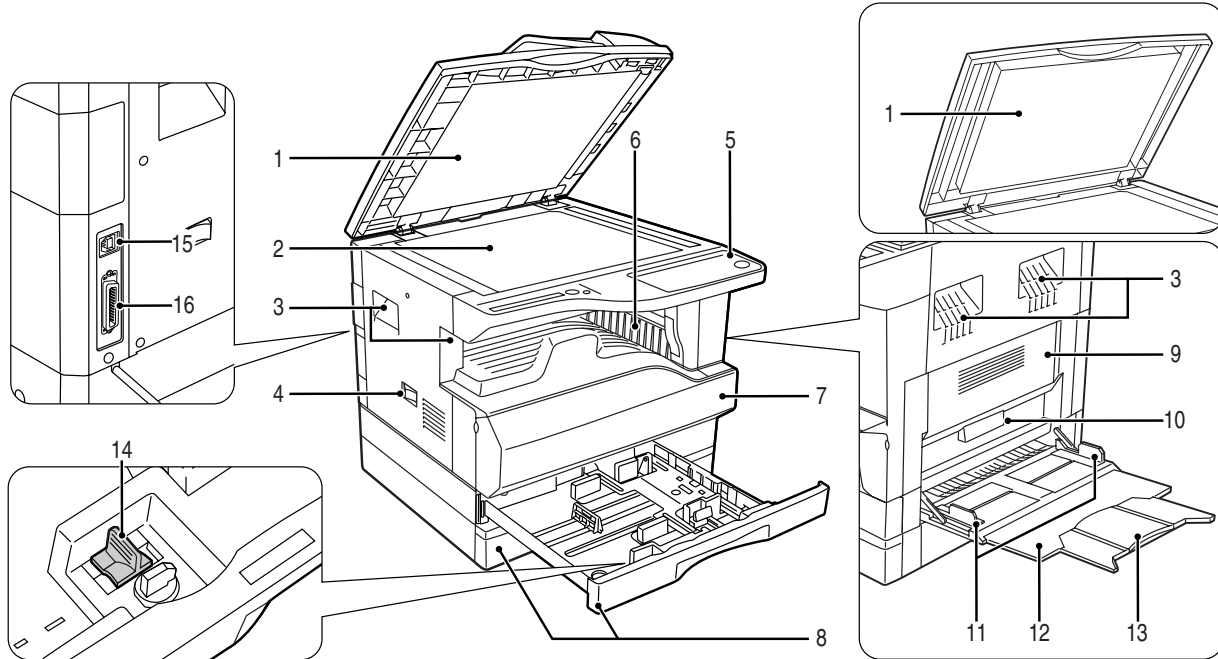

1	Document feeder cover (when the SPF is installed) /document cover	2	Document glass	3	Handles
4	Power switch	5	Operation panel	6	Paper output tray
7	Front cover	8	Paper trays	9	Side cover
10	Side cover handle	11	Bypass tray guides	12	Bypass tray
13	Bypass tray extension	14	Charger cleaner	15	USB 1.1 connector
16	Parallel connector				

2. Internal

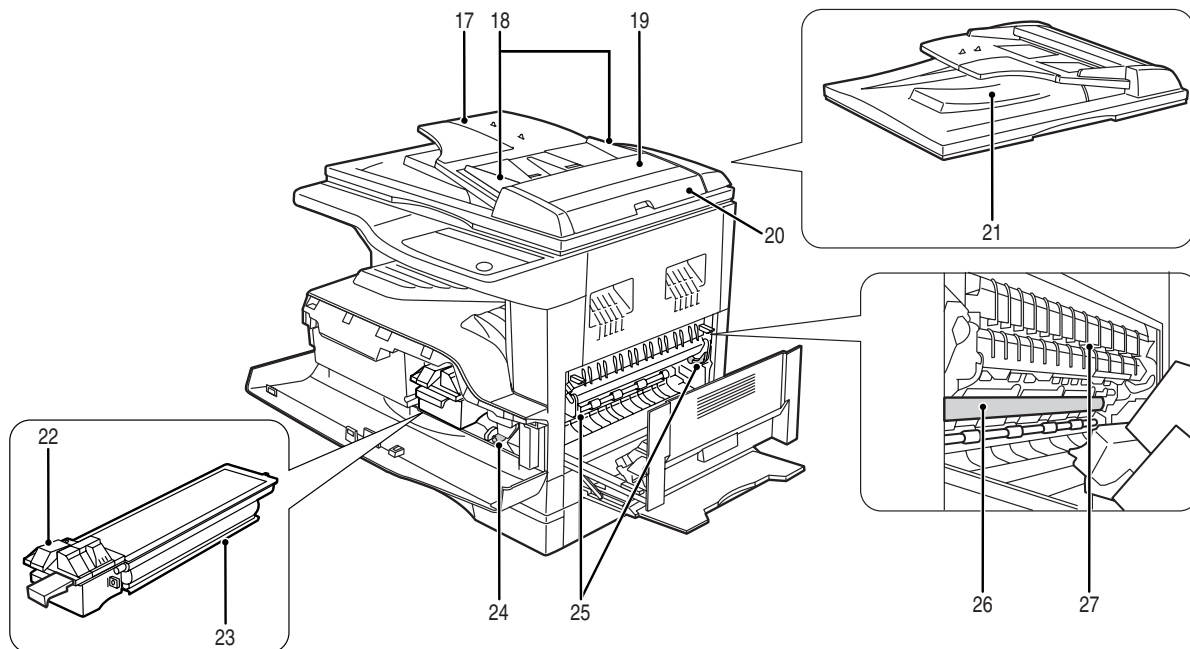

17	Document feeder tray (when the SPF is installed)	18	Original guides (when the SPF is installed)	19	Feeding roller cover (when the SPF is installed)
20	Right side cover (when the SPF is installed)	21	Exit area (when the SPF is installed)	22	Toner cartridge lock release lever
23	Toner cartridge	24	Roller rotating knob	25	Fusing unit release levers
26	Photoconductive drum	27	Fusing unit paper guide		

3. Operation Section

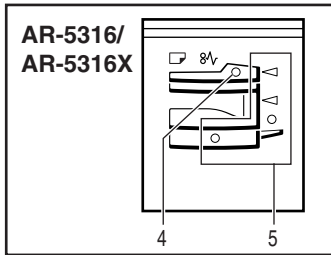
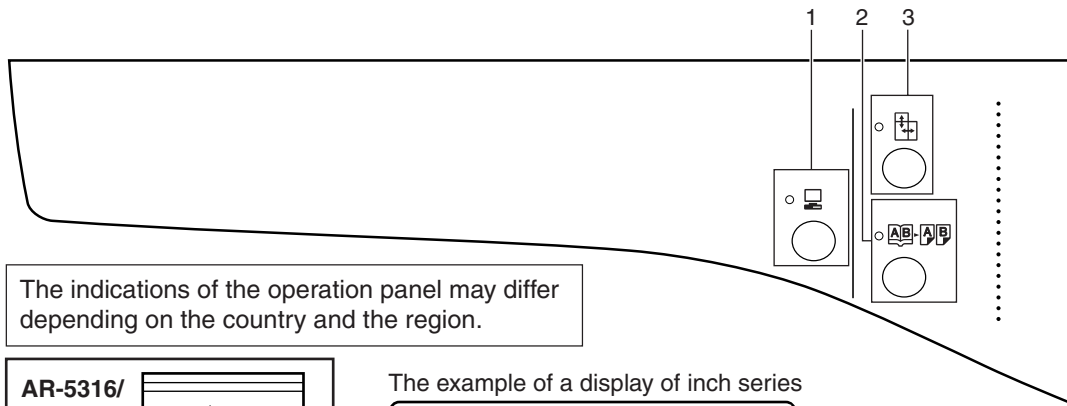

The example of a display of inch series

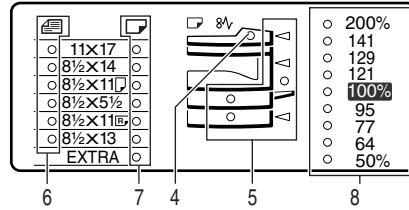

1	ON LINE key/indicator	2	DUAL PAGE COPY key/indicator	3	XY-ZOOM key/indicator
4	SPF indicator (when the SPF is installed)	5	Paper feed location / misfeed location indicators	6	ORIGINAL SIZE ENTER key / ORIGINAL SIZE indicators
7	PAPER SIZE indicators	8	PRESET RATIO selector keys / indicators		

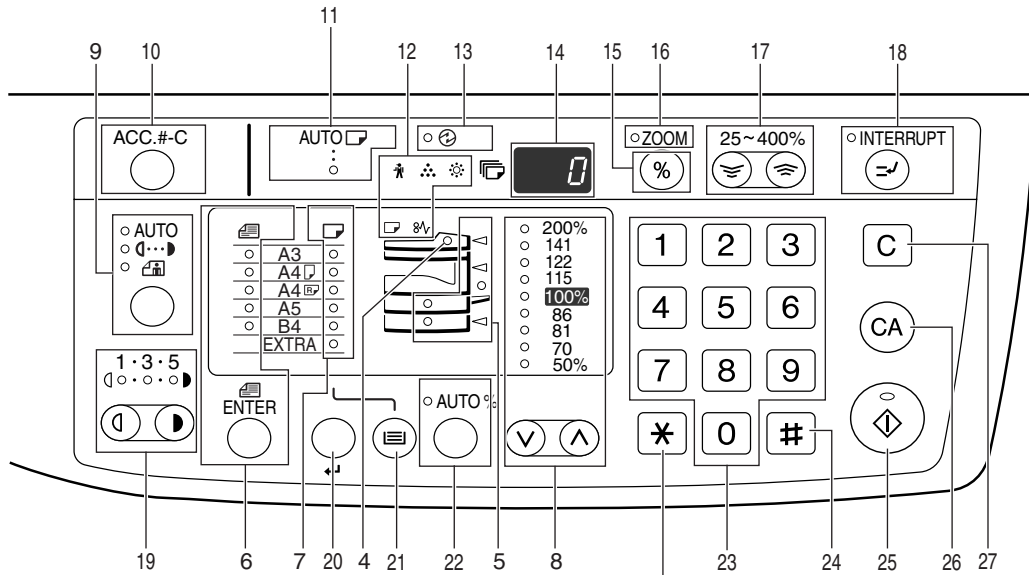

Not used for this machine.

9	AUTO/TEXT/PHOTO key / indicators	10	AUDIT CLEAR key	11	AUTO PAPER SELECT indicator
12	Alarm indicators	13	POWER SAVE indicator	14	Display
15	Copy ratio display key	16	ZOOM indicator	17	Zoom keys
18	INTERRUPT key / indicator	19	Light and Dark keys / indicators	20	PAPER SIZE ENTER key
21	TRAY SELECT key	22	AUTO IMAGE key / indicator	23	Numeric keys
24	# key	25	START key / indicator	26	CLEAR ALL key
27	CLEAR key				

[5]UNPACKING AND INSTALLATION

5. Changing a tray's paper size setting

Follow these steps to change a tray's paper size setting.

Note:

- The paper size setting cannot be changed when the machine has stopped temporarily due to running out of paper or a misfeed, or during interrupt copying.
- During printing (even in copy mode), the paper size setting cannot be changed.
- A5 size paper can only be selected in upper paper tray.
- Do not load paper that is a different size than the paper size setting. Copying will not be possible.

- 1) Hold down the [PAPER SIZE ENTER] key for more than 5 seconds to set the selected paper size.

The currently selected paper feed location indicator will blink and the corresponding paper size (which is currently set) indicator will light steadily.

All other indicators will go out.

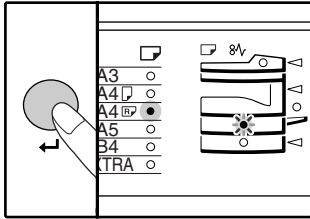

- 2) If the machine has two paper trays, use the [TRAY SELECT] key to select the paper tray for which you wish to change the paper size setting.

Each time the [TRAY SELECT] key is pressed, a paper tray will be indicated with a blinking paper feed location indicator.

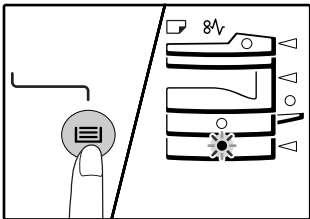

- 3) Use the [ORIGINAL SIZE ENTER] key to select the paper size. The indicator of the selected paper size lights up.

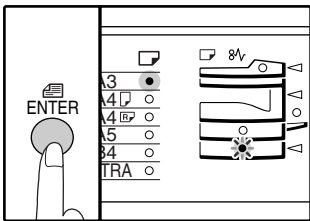

- 4) Squeeze the lock lever of the front guide and slide the front guide to match the width of the paper, and move the left guide to the appropriate slot as marked on the tray.

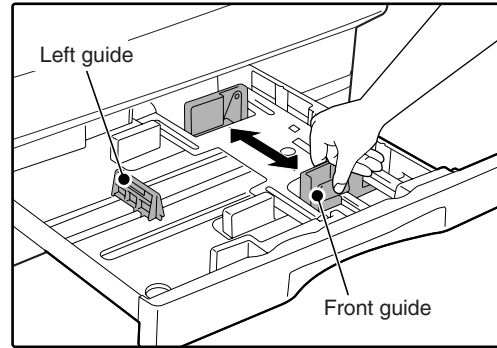

- The front guide is a slide-type guide. Grasp the locking knob on the guide and slide the guide to the indicator line of the paper to be loaded.
- The left guide is an insert-type guide. Remove it and then insert it at the indicator line of the paper to be loaded.
- When using 11" x 17" sized paper store the left guide in the slot at the left front of the paper tray.

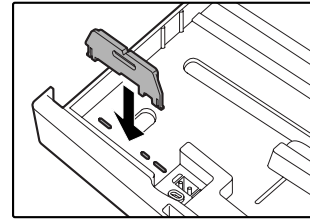

- 5) Press the [START] key and then the [PAPER SIZE ENTER] key. To change the paper size setting of another tray, repeat steps 2) to 5) after pressing the [START] key.

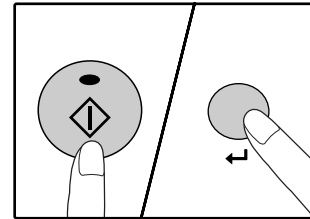

Note: Affix the paper size label for the paper size selected in step 3) to the label position on the right end of the tray.

Important points when using the printer mode

- Make sure that the tray's paper size setting is the same as the tray's paper size setting in the printer driver. For example, if the tray's paper size setting is A4R, set "Setting Paper Size" to "A4-R". For more information, see "CONFIGURING THE PRINTER DRIVER" in the "Software Setup Guide".

[7] SIMULATIONS

1. Entering the simulation mode

Perform the following procedure to enter the simulation mode.
 "#" key → Interrupt key → "C" key → Interrupt key →
 Main code → Start key → Sub code → Start key

2. Canceling the simulation mode

When the clear all key is pressed, the simulation mode is cancelled.
 When the interruption key is pressed, the process is interrupted and the screen returns to the sub code entering display.

* After canceling the simulation mode, be sure to turn OFF/ON the power and check the operation.

Note: If the machine is terminated by a jam error or paper empty during copying in the adjustment by the simulation, recopying is required.

3. List of simulations

Main code	Sub code	Contents
01	01	Mirror scanning operation
	02	Mirror home position sensor (MHPS) status display
	06	Mirror scanning operation aging
02	01	Single paper feeder (SPF) aging
	02	SPF sensor status display
	03	SPF motor operation check
	08	SPG paper feed solenoid operation check
	11	SPF PS release solenoid operation check
05	01	Operation panel display check
	02	Fusing lamp and cooling fan operation check
	03	Copy lamp lighting check
06	01	Paper feed solenoid operation check
	02	Resist roller solenoid operation check
	10	Cassette semi-circular roller cleaning
07	01	Warm-up display and aging with jam
	06	Intermittent aging
	08	Shifting with warm-up display
08	01	Developing bias output
	02	Main charger output (Grid = HIGH)
	03	Main charger output (Grid = LOW)
	06	Transfer charger output
10	-	Toner motor operation
14	-	Trouble cancel (except for U2)
16	-	U2 trouble cancel
20	01	Maintenance counter clear
21	01	Maintenance cycle setting
	02	Mini maintenance cycle setting
22	01	Maintenance counter display
	02	Maintenance preset display
	03	Jam memory display
	04	Jam total counter display
	05	Total counter display
	06	Developing counter display
	07	Mini maintenance preset display
	08	SPF counter display
	09	Paper feed counter display
	12	Drum counter display
	13	CRUM type display
	14	P-ROM version display

Main code	Sub code	Contents	
22	15	Trouble memory display	
	17	Copy counter display	
	18	Printer counter display	
	21	Scanner counter display	
	22	SPF jam counter display	
24	01	Jam total counter clear	
	02	Trouble memory clear	
	04	SPF counter clear	
	06	Paper feed counter clear	
	07	Drum counter clear	
	08	Copy counter clear	
	09	Printer counter clear	
	13	Scanner counter clear	
	14	SPF jam total counter clear	
	25	01	Main motor operation check
10		Polygon motor operation check	
26	02	Size setting	
	03	Auditor setting	
	05	Count mode setting	
	06	Destination setting	
	07	Machine condition check (CPM)	
	18	Toner save mode setting	
	30	CE mark conformity control ON/OFF	
	31	Auditor mode exclusive setup	
	36	Cancel of stop at maintenance life over	
	37	Cancel of stop at developer life over	
	38	Cancel of stop at drum life over	
30	39	Memory capacity check	
	42	Transfer ON/OFF timing control setting	
	43	Side void amount setting	
	51	Copy temporary stop function setting	
	01	Paper sensor status display	
	01	Developing counter clear	
	43	01	Fusing temperature setting
		12	Standby mode fusing fan rotation setting
13		Fusing paper interval control allow/inhibit setting	
44	34	Transfer current setting	
	40	Setting of rotation time before toner supply	
46	01	Copy density adjustment (300dpi)	
	02	Copy density adjustment (600dpi)	
	09	Copy exposure level adjustment, individual setting (Text) 300dpi	
	10	Copy exposure level adjustment, individual setting (Text) 600dpi	
	11	Copy exposure level adjustment, individual setting (Photo) 600dpi	
	18	Image contrast adjustment (300dpi)	
	19	Exposure mode setting (Gamma table setting/AE operation mode setting/ Photo image process setting)	
	20	SPF exposure correction	
	29	Image contrast adjustment (600dpi)	
	30	AE limit setting	
	31	Image sharpness adjustment	
48	01	Main scanning magnification ratio adjustment	
	05	SPF/RSPF mode sub scanning magnification ratio adjustment in copying	
49	01	Flash ROM program writing mode	
	12	Standby mode fusing fan RPM setting	

Main code	Sub code	Contents
50	01	Image lead edge adjustment
	06	Copy lead edge position adjustment (SPF/RSPF)
	10	Paper off-center adjustment
	12	Document off-center adjustment
51	02	Resist amount adjustment
53	08	SPF scanning position automatic adjustment
	10	SPF scan position change-over setting
61	03	HSYNC output check
63	01	Shading check
	07	SPF automatic correction
64	01	Self print

4. Contents of simulations

Main code	Sub code	Contents	Details of operation																						
01	06	Mirror scanning operation aging	<p>When the [START] key is pressed, the mirror base performs A3 full scanning at the set magnification ratio speed. During scanning, the set magnification ratio is displayed. After 3 seconds, the mirror base performs full scanning again. During scanning, the set magnification ratio is displayed.</p> <p>* When the [START] key is pressed again, the ready lamp turns and remains off. The DV replacement/OPC drum cartridge replacement lamp displays the status of the mirror home position sensor. (The lamp lights up when the mirror is in the home position.) During aging, the copy lamp lights up. When the [Interrupt] key is pressed, the operation is interrupted if operating, and the machine goes into the sub code input standby mode.</p>																						
02	01	Single paper feeder (SPF) aging	<p>When the [START] key is pressed, the set magnification ratio is acquired and document transport operation of single surface is performed in the case of SPF or document transport operation of duplex surfaces is performed. During operation, the LED on the display section corresponding to the selected magnification ratio lights up, and the magnification ratio is displayed on the 7-seg display. When the [Interrupt] key is pressed at that time, the machine goes to the sub code input standby mode. When the [CA] key is pressed, the simulation is terminated.</p>																						
	02	SPF sensor status display	<p>(In order to receive the sensor change notification, the load must be decreased.) The sensor status (ON/OFF) in the SPF can be checked with the following lamps. When a sensor detects paper, it turns on. The open/close detection sensor turns on when the machine is opened.</p> <table border="1"> <thead> <tr> <th>Display lamp</th> <th>Sensor</th> </tr> </thead> <tbody> <tr> <td>Toner supply lamp</td> <td>SPF document set sensor</td> </tr> <tr> <td>Copier jam lamp</td> <td>SPF document transport sensor</td> </tr> <tr> <td>The DV replacement/OPC drum cartridge replacement lamp</td> <td>SPF unit (OC cover) open/close sensor</td> </tr> <tr> <td>Paper empty lamp</td> <td>SPF paper exit sensor</td> </tr> <tr> <td>SPF jam lamp</td> <td>SPF paper feed cover open/close sensor</td> </tr> <tr> <td>Manual paper feed lamp</td> <td>SPF paper length sensor 1</td> </tr> <tr> <td>Tray jam lamp</td> <td>SPF paper length sensor 2</td> </tr> <tr> <td>AE lamp</td> <td>SPF paper feed width sensor (small)</td> </tr> <tr> <td>TEXT lamp</td> <td>SPF paper feed width sensor (middle)</td> </tr> <tr> <td>PHOTO lamp</td> <td>SPF paper feed width sensor (large)</td> </tr> </tbody> </table> <p>When the [Interrupt] key is pressed, the machine goes to the sub code input standby mode. When the [CA] key is pressed, the simulation is terminated.</p>	Display lamp	Sensor	Toner supply lamp	SPF document set sensor	Copier jam lamp	SPF document transport sensor	The DV replacement/OPC drum cartridge replacement lamp	SPF unit (OC cover) open/close sensor	Paper empty lamp	SPF paper exit sensor	SPF jam lamp	SPF paper feed cover open/close sensor	Manual paper feed lamp	SPF paper length sensor 1	Tray jam lamp	SPF paper length sensor 2	AE lamp	SPF paper feed width sensor (small)	TEXT lamp	SPF paper feed width sensor (middle)	PHOTO lamp	SPF paper feed width sensor (large)
Display lamp	Sensor																								
Toner supply lamp	SPF document set sensor																								
Copier jam lamp	SPF document transport sensor																								
The DV replacement/OPC drum cartridge replacement lamp	SPF unit (OC cover) open/close sensor																								
Paper empty lamp	SPF paper exit sensor																								
SPF jam lamp	SPF paper feed cover open/close sensor																								
Manual paper feed lamp	SPF paper length sensor 1																								
Tray jam lamp	SPF paper length sensor 2																								
AE lamp	SPF paper feed width sensor (small)																								
TEXT lamp	SPF paper feed width sensor (middle)																								
PHOTO lamp	SPF paper feed width sensor (large)																								
06	01	Paper feed solenoid operation check	<p>When this simulation is executed, the sub code is displayed on the 7-seg LED and the lamp corresponding to the solenoid lights up. Select a solenoid with the tray select key (the lamp corresponding to the solenoid lights up) and press the [START] key, and the machine repeats operation of ON for 500ms and OFF for 500ms. This operation is repeated 20 times. After that, the machine goes into the sub code entry standby mode. When [INTERRUPT] key is pressed during the process, the machine goes into the sub code input standby mode. When [CA] key is pressed, the simulation is terminated.</p> <table border="1"> <thead> <tr> <th>Display lamp</th> <th>Solenoid</th> </tr> </thead> <tbody> <tr> <td>Main cassette lamp</td> <td>Main cassette paper feed solenoid</td> </tr> <tr> <td>2nd cassette lamp</td> <td>* 2nd cassette paper feed solenoid</td> </tr> <tr> <td>Manual paper feed lamp</td> <td>Manual paper feed solenoid</td> </tr> <tr> <td>2nd cassette jam lamp</td> <td>* 2nd cassette paper transport solenoid</td> </tr> <tr> <td>Machine jam lamp & 2nd cassette jam lamp</td> <td>* 3rd cassette transport solenoid</td> </tr> </tbody> </table> <p>* Supported for the installed models only. Skipped for the models without installation.</p>	Display lamp	Solenoid	Main cassette lamp	Main cassette paper feed solenoid	2nd cassette lamp	* 2nd cassette paper feed solenoid	Manual paper feed lamp	Manual paper feed solenoid	2nd cassette jam lamp	* 2nd cassette paper transport solenoid	Machine jam lamp & 2nd cassette jam lamp	* 3rd cassette transport solenoid										
Display lamp	Solenoid																								
Main cassette lamp	Main cassette paper feed solenoid																								
2nd cassette lamp	* 2nd cassette paper feed solenoid																								
Manual paper feed lamp	Manual paper feed solenoid																								
2nd cassette jam lamp	* 2nd cassette paper transport solenoid																								
Machine jam lamp & 2nd cassette jam lamp	* 3rd cassette transport solenoid																								

Main code	Sub code	Contents	Details of operation								
06	02	Resist roller solenoid operation check	When the [START] key is pressed in the sub code input state, the resist solenoid (RRS) turns ON for 500ms and OFF for 500ms. This operation is repeated 20 times. After completion of the process, the machine goes into the sub code input standby mode. When [INTERRUPT] key is pressed during the process, the machine goes into the sub code input standby mode. When [CA] key is pressed, the simulation is terminated.								
	10	Cassette semi-circular roller cleaning	First of all, remove the developer unit. Enter the simulation code, specify the cassette to be cleaned with the tray select key, and press START button. The main motor rotates to move the cassette semi-circular roller by half circle and make the roller face downward. After completion of cleaning, when INTERRUPT key is pressed, the machine goes into the sub code entry standby mode and the roller returns to the original positions. To clean another roller continuously, press INTERRUPT key to return the roller to the original position, and execute the simulation again. During the operation, the sub code is displayed on the display. * When CA key is pressed, the simulation mode is terminated. However, the roller returns to the original position by the initial operation.								
08	01	Developing bias output	When the [START] key is pressed, the developing bias signal is turned ON for 30 sec. However, to calculate the actual output value is calculated, execute SIM25-01. After completion of the process, the machine goes into the sub code input standby mode. When [INTERRUPT] key is pressed during the process, the machine goes into the sub code input standby mode. When [CA] key is pressed, the simulation is terminated.								
	02	Main charger output (Grid = HIGH)	When the [START] key is pressed, the main charger output is supplied for 30 sec in the grid voltage HIGH mode. After completion of the process, the machine goes into the sub code input standby mode. When [INTERRUPT] key is pressed during the process, the machine goes into the sub code input standby mode. When [CA] key is pressed, the simulation is terminated.								
	03	Main charger output (Grid = LOW)	When the [START] key is pressed, the main charger output is supplied for 30 sec in the grid voltage LOW mode. After completion of the process, the machine goes into the sub code input standby mode. When [INTERRUPT] key is pressed during the process, the machine goes into the sub code input standby mode. When [CA] key is pressed, the simulation is terminated.								
	06	Transfer charger output	Select an output mode with the [Mode select] key and press the [START] key. The transfer charger output is delivered for 30 sec in the selected mode. After 30 sec of transfer charger output, the machine goes into the sub code entry standby mode. When [INTERRUPT] key is pressed during the process, the machine goes into the sub code input standby mode. When [CA] key is pressed, the simulation is terminated.								
			<table border="1"> <thead> <tr> <th>Display lamp</th> <th>Output mode</th> </tr> </thead> <tbody> <tr> <td>AE mode lamp</td> <td>Normal size width: Front surface</td> </tr> <tr> <td>AE mode lamp & PHOTO mode lamp</td> <td>Small size width: Front surface</td> </tr> <tr> <td>AE & TEXT & PHOTO mode lamp</td> <td>Manual paper feed mode</td> </tr> </tbody> </table> <p>•Small size is Letter R (A4R) or smaller.</p>	Display lamp	Output mode	AE mode lamp	Normal size width: Front surface	AE mode lamp & PHOTO mode lamp	Small size width: Front surface	AE & TEXT & PHOTO mode lamp	Manual paper feed mode
Display lamp	Output mode										
AE mode lamp	Normal size width: Front surface										
AE mode lamp & PHOTO mode lamp	Small size width: Front surface										
AE & TEXT & PHOTO mode lamp	Manual paper feed mode										
22	01	Maintenance counter display	The maintenance counter value is displayed. (Alternate display by 3 digits)								
	04	Jam total counter display	The jam total counter value is displayed. (Alternate display by 3 digits)								
	05	Total counter display	The total counter value is displayed. (Alternate display by 3 digits)								
	06	Developing counter display	The developing counter data is acquired and displayed on the 7-seg display. (Alternate display by 3 digits) When the [Interrupt] key is pressed, the machine goes into the sub code input standby mode. When the [CA] key is pressed, the simulation is terminated.								
	08	SPF counter display	The SPF counter value is displayed. (Alternate display by 3 digits)								
	14	P-ROM version display	The P-ROM version is displayed on the copy quantity display. The main code and the sub code are alternatively displayed by 2 digits. The display interval is same as that of the counter display. By pressing the fixed magnification ratio key, each version display is switched.								
				<table border="1"> <thead> <tr> <th>Display lamp (AB series)</th> <th>Display lamp (Inch series)</th> <th>Displayed version</th> </tr> </thead> <tbody> <tr> <td>141%</td> <td>141%</td> <td>Machine program</td> </tr> </tbody> </table>	Display lamp (AB series)	Display lamp (Inch series)	Displayed version	141%	141%	Machine program	
	Display lamp (AB series)	Display lamp (Inch series)	Displayed version								
141%	141%	Machine program									
17	Copy counter display	The copy counter value is displayed. (Alternate display by 3 digits) When the [Interrupt] key is pressed, the machine goes into the sub code input standby mode. When the [CA] key is pressed, the simulation is terminated.									
18	Printer counter display	The printer counter value is displayed. (Alternate display by 3 digits) When the [Interrupt] key is pressed, the machine goes into the sub code input standby mode. When the [CA] key is pressed, the simulation is terminated.									
21	Scanner counter display	The scanner counter value is displayed. (Alternate display by 3 digits) When the [Interrupt] key is pressed, the machine goes into the sub code input standby mode. When the [CA] key is pressed, the simulation is terminated.									

Main code	Sub code	Contents	Details of operation																																												
22	22	SPF jam counter display	The SPF jam counter value is displayed. (Alternate display by 3 digits)When the [Interrupt] key is pressed, the machine goes into the sub code input standby mode. When the [CA] key is pressed, the simulation is terminated.																																												
44	34	Transfer current setting	<p>Used to set the transfer current for the front surface and that for the back surface. When this simulation is executed, the current set value is displayed on the 7-seg display. Select the set value with the zoom (Up/Down) keys and press the [START] key, and the set content is written into the EEPROM and the machine goes into the sub code input standby mode. Press the [Mode select] key to select each setting mode. At that time, the setup content is written into the EEPROM. The set range is 90uA ~ 360uA in the increment of 10uA.</p> <table border="1"> <thead> <tr> <th>Display lamp</th> <th>Setting mode</th> </tr> </thead> <tbody> <tr> <td>AE mode lamp</td> <td>Normal size width: Front</td> </tr> <tr> <td>AE mode lamp & PHOTO mode lamp</td> <td>Small size width: Front</td> </tr> <tr> <td>AE & TEXT & PHOTO mode lamps</td> <td>Manual paper feed</td> </tr> </tbody> </table> <p>* Small size paper must be Letter R (A4R) or smaller. * For the special size of tray, use the normal size width.</p>	Display lamp	Setting mode	AE mode lamp	Normal size width: Front	AE mode lamp & PHOTO mode lamp	Small size width: Front	AE & TEXT & PHOTO mode lamps	Manual paper feed																																				
Display lamp	Setting mode																																														
AE mode lamp	Normal size width: Front																																														
AE mode lamp & PHOTO mode lamp	Small size width: Front																																														
AE & TEXT & PHOTO mode lamps	Manual paper feed																																														
49	01	Flash ROM program writing mode	<p>(Operating procedure) When this simulation is executed, "d" is displayed on the copy quantity display and the machine enters the Flash ROM program writing mode. Use the writing tool on the PC to write the program. During writing, the display is made as follows. After completion of downloading, turn OFF/ON the power to reset.</p> <table border="1"> <thead> <tr> <th>Status</th> <th>Copy quantity display</th> <th>Pre-heat lamp</th> <th>Ready lamp</th> </tr> </thead> <tbody> <tr> <td>Download data reception</td> <td>"d"</td> <td>ON</td> <td>OFF</td> </tr> <tr> <td>Data delete start</td> <td>"d"</td> <td>ON</td> <td>ON</td> </tr> <tr> <td>Data writing (Boot section)</td> <td>"d"</td> <td>Flash</td> <td>OFF</td> </tr> <tr> <td>Data writing (Program section)</td> <td>"d"</td> <td>Flash</td> <td>Flash</td> </tr> <tr> <td>Sum check</td> <td>"d"</td> <td>ON</td> <td>ON</td> </tr> <tr> <td>Completion of downloading</td> <td>"OFF"</td> <td>OFF</td> <td>OFF</td> </tr> <tr> <td>Error status</td> <td>"*E"</td> <td>OFF</td> <td>OFF</td> </tr> </tbody> </table> <p>* "*" in the error display indicates the error position.</p> <table border="1"> <tbody> <tr> <td>00 Data receive error</td> <td>07 Sum check error (Program section)</td> </tr> <tr> <td>02 FLASH ROM delete error</td> <td>08 Sum check error (EEPROM section)</td> </tr> <tr> <td>03 FLASH ROM write error (Boot section)</td> <td>09 E2PROM verify error</td> </tr> <tr> <td>04 FLASH ROM write error (Program section)</td> <td>0b E2PROM verify error</td> </tr> <tr> <td>05 Sum check error (Loader section)</td> <td>0F Download data length error</td> </tr> <tr> <td>06 Sum check error (Boot section)</td> <td></td> </tr> </tbody> </table>	Status	Copy quantity display	Pre-heat lamp	Ready lamp	Download data reception	"d"	ON	OFF	Data delete start	"d"	ON	ON	Data writing (Boot section)	"d"	Flash	OFF	Data writing (Program section)	"d"	Flash	Flash	Sum check	"d"	ON	ON	Completion of downloading	"OFF"	OFF	OFF	Error status	"*E"	OFF	OFF	00 Data receive error	07 Sum check error (Program section)	02 FLASH ROM delete error	08 Sum check error (EEPROM section)	03 FLASH ROM write error (Boot section)	09 E2PROM verify error	04 FLASH ROM write error (Program section)	0b E2PROM verify error	05 Sum check error (Loader section)	0F Download data length error	06 Sum check error (Boot section)	
Status	Copy quantity display	Pre-heat lamp	Ready lamp																																												
Download data reception	"d"	ON	OFF																																												
Data delete start	"d"	ON	ON																																												
Data writing (Boot section)	"d"	Flash	OFF																																												
Data writing (Program section)	"d"	Flash	Flash																																												
Sum check	"d"	ON	ON																																												
Completion of downloading	"OFF"	OFF	OFF																																												
Error status	"*E"	OFF	OFF																																												
00 Data receive error	07 Sum check error (Program section)																																														
02 FLASH ROM delete error	08 Sum check error (EEPROM section)																																														
03 FLASH ROM write error (Boot section)	09 E2PROM verify error																																														
04 FLASH ROM write error (Program section)	0b E2PROM verify error																																														
05 Sum check error (Loader section)	0F Download data length error																																														
06 Sum check error (Boot section)																																															
	12	Standby mode fusing fan RPM setting	<p>When this simulation is executed, the currently set code number is displayed. When [MODE SELECT] key is pressed, the normal setting and the high fusing temperature setting are switched alternatively. Enter the code number and press START key, and the number is written into the EEPROM and the machine goes into the sub code entry standby mode.</p> <table border="1"> <thead> <tr> <th>Display lamp</th> <th>Setting mode</th> <th>Default</th> </tr> </thead> <tbody> <tr> <td>AE mode lamp</td> <td>Normal temperature control (190°C or less)</td> <td>Low speed rotation</td> </tr> <tr> <td>TEXT mode</td> <td>Fusing temperature of 190°C or above</td> <td>High speed rotation</td> </tr> </tbody> </table> <table border="1"> <thead> <tr> <th>Code number</th> <th>Setting</th> </tr> </thead> <tbody> <tr> <td>0</td> <td>Low speed rotation</td> </tr> <tr> <td>1</td> <td>High speed rotation</td> </tr> </tbody> </table>	Display lamp	Setting mode	Default	AE mode lamp	Normal temperature control (190°C or less)	Low speed rotation	TEXT mode	Fusing temperature of 190°C or above	High speed rotation	Code number	Setting	0	Low speed rotation	1	High speed rotation																													
Display lamp	Setting mode	Default																																													
AE mode lamp	Normal temperature control (190°C or less)	Low speed rotation																																													
TEXT mode	Fusing temperature of 190°C or above	High speed rotation																																													
Code number	Setting																																														
0	Low speed rotation																																														
1	High speed rotation																																														

Main code	Sub code	Contents	Details of operation										
51	02	Resist amount adjustment	<p>Used to adjust the contact pressure of the machine resist roller and the RSPF resist roller onto the paper.</p> <p>(Operating procedure) When this simulation is executed, the current set value is displayed. When the exposure mode key is pressed, the following set items are changed sequentially. Enter an adjustment value with the 10-key and press the [START] key, and the entered value will be saved and a copy will be made. (Adjustment range: 1 ~ 99, Default: 50) When the [CA] key is pressed, the entered value is saved and the simulation is terminated.</p> <table border="1"> <thead> <tr> <th>Lighting lamp</th> <th>Adjustment mode</th> </tr> </thead> <tbody> <tr> <td>AE, Main cassette lamp</td> <td>Main cassette paper feed</td> </tr> <tr> <td>AE, 2nd cassette lamp</td> <td>★ 2nd cassette paper feed</td> </tr> <tr> <td>AE, Manual paper feed lamp</td> <td>Manual paper feed</td> </tr> <tr> <td>AE, TEXT, PHOTO lamps</td> <td>★ SPF document feed (Front surface)</td> </tr> </tbody> </table> <p>★ Supported for the installed models only. Skipped for the models without installation.</p>	Lighting lamp	Adjustment mode	AE, Main cassette lamp	Main cassette paper feed	AE, 2nd cassette lamp	★ 2nd cassette paper feed	AE, Manual paper feed lamp	Manual paper feed	AE, TEXT, PHOTO lamps	★ SPF document feed (Front surface)
Lighting lamp	Adjustment mode												
AE, Main cassette lamp	Main cassette paper feed												
AE, 2nd cassette lamp	★ 2nd cassette paper feed												
AE, Manual paper feed lamp	Manual paper feed												
AE, TEXT, PHOTO lamps	★ SPF document feed (Front surface)												
53	10	SPF scan position change-over setting	<p>Used to change over the scan position depending on that the SPF unit and the SPF document glass holder section are of anti-dirt glass or not.</p> <p>When this simulation is executed, the currently set code number is displayed. Enter the code number corresponding to the SPF unit to be used and press [START] key, and the setting will be changed over.</p> <table border="1"> <thead> <tr> <th>Code No.</th> <th>Mode</th> </tr> </thead> <tbody> <tr> <td>0</td> <td>Set to the scan position of the current mass production SPF unit. (Default)</td> </tr> <tr> <td>1</td> <td>Set to the scan position of the ant-dirt SPF unit.</td> </tr> </tbody> </table> <p>Though this setting is changed, the other set values are not affected. (The other set values remain unchanged.) When replacing and installing the SPF unit, it is recommendable to use this simulation to set the scan position and execute the scan position automatic adjustment.</p>	Code No.	Mode	0	Set to the scan position of the current mass production SPF unit. (Default)	1	Set to the scan position of the ant-dirt SPF unit.				
Code No.	Mode												
0	Set to the scan position of the current mass production SPF unit. (Default)												
1	Set to the scan position of the ant-dirt SPF unit.												
64	01	Self print	<p>The optical system status is ignored and a self print is made. Also when a print command is sent from the host, printing is performed.</p> <p>(Operating procedure) When this simulation is executed, warm-up is performed and the ready lamp is lighted. (However, the scanner is invalid and no initial operation is made.) Enter the code number with the 10-key, and select a cassette with the cassette select key and press the [START] key. The selected cassette start paper feed and printing is performed in the selected pattern.</p> <p>* Only the tray lamp and the online lamp are lighted, and no other lamps are lighted. Printing is made in 1 by 2 mode, where one line is printed and the following two lines are not printed, or in the grid pattern.</p> <table border="1"> <thead> <tr> <th>Code number</th> <th>Pattern</th> </tr> </thead> <tbody> <tr> <td>0</td> <td>1 by 2</td> </tr> <tr> <td>1</td> <td>Grid pattern</td> </tr> <tr> <td>2</td> <td>White paper</td> </tr> <tr> <td>3</td> <td>Black background</td> </tr> </tbody> </table> <p>* Input disable for 4 ~ 99 * Print data are made on A3 size. (A3 paper is preferable.)</p>	Code number	Pattern	0	1 by 2	1	Grid pattern	2	White paper	3	Black background
Code number	Pattern												
0	1 by 2												
1	Grid pattern												
2	White paper												
3	Black background												

[8] USER PROGRAMS

The user programs allow the parameters of certain functions to be set, changed, or canceled as desired.

1. List of user programs

This copier has the following user programs.

Program name	Program No	Description	Default	Parameters
Auto clear time	1	"Auto clear time" automatically returns the copy settings to the initial settings when a certain period of time elapses after a copy is made. This program is used to select the period of time. "Auto clear time" can also be disabled.	60sec	1 (OFF) 2 (10sec) 3 (20sec) 4 (60sec) 5 (90sec) 6 (120sec)
Preheat mode	2	This function automatically switches the machine to a low power consumption state if the set duration of time elapses without the machine being used when the power is on. The POWER SAVE indicator lights up, however, the keys on the operation panel can be used. Normal operation automatically resumes when a key on the operation panel is pressed, a print job is received or an original is placed.	1min	1 (1min) 2 (5min) 3 (30min) 4 (60min) 5 (120min) 6 (240min)
Auto power shut-off timer	3	This function automatically switches the machine to a state that consumes even less power than preheat mode if the set duration of time elapses without the machine being used when the power is on. All lights except the POWER SAVE indicator and ON LINE indicator go off. To resume normal operation, press the [START] key. Normal operation also resumes automatically when a print job is received or scanning is begun from a computer. While in auto power shut-off mode, no keys (except the [START] key) can be used.	5min	1 (5min) 2 (30min) 3 (60min) 4 (120min) 5 (240min)
Stream feeding mode *1	4	When copying using the SPF, during the period of time that the SPF indicator blinks after an original has been scanned (about 5 seconds), a subsequent original can be placed and automatically fed into the machine.	OFF	0 (OFF) 1 (ON)
Auto power shut-off setting	5	Use this setting to enable or disable auto power shut-off.	ON	0 (OFF) 1 (ON)
Auto paper select mode *2	8	This function automatically selects paper that is the same size as the original placed in the SPF, or the same size as that selected with the [ORIGINAL SIZE ENTER] key. The function can be disabled.	ON	0 (OFF) 1 (ON)
Auto tray switching *2	9	If the paper runs out during printing and there is paper of the same size and orientation in another tray, this function automatically switches to that tray (excluding the bypass tray). The function can be disabled.	ON	0 (OFF) 1 (ON)
Auditing mode	10	Use to enable or disable "Auditing mode". "Auditing mode" is initially disabled.	OFF	0 (OFF) 1 (ON)
Account number entry	11	Use to set up account numbers. Up to 20 accounts can be established.	-	-
Account number change	12	Use to change an account number.	-	-
Account number deletion	13	Use to delete an account number. A single account number can be deleted, or all account numbers at once.	Delete single account	0 (Delete single account) 1 (Delete all accounts)
Number of copies per account	14	This displays the number of copies made by each account. The maximum count is 49,999. If this number is exceeded, the count will start over from 0.	-	-
Resetting account	15	Use to reset the copy count of an account to 0. The copy count of a single account or of all accounts can be reset.	Reset single account	0 (Reset single account) 1 (Reset all accounts)
Resolution in Auto/Text mode	23	This setting is used to change the copy resolution in AUTO and TEXT mode from 600 x 300 dpi to 600 x 600 dpi (high-quality mode). Scanning is slower when high-quality mode is used.	300dpi	1 (300dpi) 2 (600dpi)

*1 On models with a SPF.

*2 On model with the two trays.

Program name	Program No	Description	Default	Parameters
Key auto repeat	25	Use this setting to select whether or not holding down a key causes repeated input of the key. For keys that normally cause a set value to increase when held down (for example, holding down the [ZOOM] key), this program can be used to have the set value not change when the key is held down.	ON	0 (OFF)
				1 (ON)
Key press time	26	Use this setting to select how long a key must be pressed for the input to be accepted. By selecting a longer time, you can prevent settings from being changed by the accidental pressing of a key.	Minimum (current response speed)	1 (Minimum (current response speed))
				2 (0.5sec)
				3 (1.0sec)
				4 (1.5sec)
				5 (2.0sec)
Audible signals volume	27	This sets the volume of beep signals.	short beep	1 (short beep)
				2 (long beep)
				3 (OFF)
Base setting beep signal	28	Use this to sound a beep when a base setting is selected.	OFF	0 (OFF)
				1 (ON)
Number of copies limit	29	Use this setting to select 99 or 999 for the maximum number of copies.	999 copies	1 (99 copies)
				2 (999 copies)
Use close paper size	30	When this function is enabled, printing in printer mode will automatically continue using a different size of paper if the specified size of paper runs out in all trays. This feature does not function in copy mode.	OFF	0 (OFF)
				1 (ON)
Default tray setting	31	Use this program to select a default tray. This tray is automatically selected each time the power is turned on or each time the machine reverts to the initial settings.	Upper paper tray	1 (Upper paper tray)
				2 (Lower paper tray)
				5 (Bypass tray)
Default exposure mode	32	Use this program to set "AUTO", "TEXT", or "PHOTO" as the default exposure mode.	AUTO	1 (AUTO)
				2 (TEXT)
				3 (PHOTO)

[10] MAINTENANCE

1. Maintenance table

X:Check(Clean, adjust, or replace when required.) O:Clean ▲:Replace △:Adjust ☆:Lubricate

Unit name	Part name	When calling	50K	100K	150K
Drum peripheral	OPC drum	-	▲	▲	▲
	Cleaning blade	-	▲	▲	▲
	Side seal F/R	X	X	X	X
	MC unit	X	▲	▲	▲
	(MC charging electrode)	-	(▲)	(▲)	(▲)
	(MC grid)	-	(▲)	(▲)	(▲)
	(MC case)	-	(▲)	(▲)	(▲)
	Transfer wire	O	O	O	O
	Transfer paper guide	O	O	O	O
	MC guide sheet (Cleaning blade attached)	-	▲	▲	▲
	Drum fixing plate B	X	▲	▲	▲
	Process frame unit	X	X	X	▲
	Discharge holder	O	O	O	O
	Separation pawl Star ring x 2 pcs	} Only for Viet Nam	X	▲	▲
Developing section	Developer	-	▲	▲	▲
	DV seal	-	X	X	▲
	DV under seal	-	-	-	▲
	DV side seal	-	X	X	▲
	Side Mylar	-	-	-	▲
Optical section	Lamp unit	Reflector	O	O	O
		Mirror	O	O	O
	No.2/3 mirror unit	Mirror	O	O	O
		Pulley	X	X	X
	CCD peripheral	Lens	O	O	O
	Glass	Table glass	O	O	O
		White Plate	O	O	O
	Other	Drive wire	X	X	X
		Rail	X ☆	X ☆	X ☆
		Document cover	O	O	O
Document size sensor		O	O	O	
LSU	Dust-proof glass	O	O	O	
Paper feed section	Multi paper feed section	Take-up roller(manual / SPF)	O	O	O
		Paper feed roller	O	O	O
		Spring clutch	O ☆	O ☆	O ☆
Paper transport section		PS roller	O	O	O
		Transport (paper exit) rollers	O	O	O
		Spring clutch	O ☆	O ☆	O ☆
Fusing section		Upper heat roller	O	O	▲
		Pressure roller	O	O	O
		Pressure roller bearing	X	X	X
		Upper separation pawl	X	X	X
		Lower separation pawl	X	X	X
		Cleaning pad	X	X	X
Drive section		Gears	X ☆	X ☆	X ☆
		Belts	X	X	X
Paper exit section		Ozone filter*1	X	X	X

*1:Recommendable replacement time:50K(Letter,5%print)

2. Maintenance display system

Toner	Life,	16K	
	Remaining quantity check *1	a. Press and hold the density adjustment LIGHT key for more than 5 sec, and the machine will enter the user program mode. b. Press and hold the "%" key for more than 5 sec, and the remaining quantity will be displayed on the copy quantity display in one of the following levels: (Remaining quantity display levels: 100%, 75%, 50%, 25%, 10%, LO) c. Press the density adjustment LIGHT key to cancel.	
	Remaining quantity	NEAR EMPTY About 10%	EMPTY
	LED	ON	Flash
	Machine	Operation allowed	Stop
Developer	Life	50K	
	LED	ON at 50K of the developer count	
	Machine	Selection is available between Not Stop and Stop by Service Simulation (SIM 26-37) Setup. (If Stop is selected, the LED will flash and stop at 50K.) * Default: Not Stop * Clear: SIM 42-1	
Maintenance	LED	Selection is available among 50K, 25K, 10K, 7.5K, 5K, and free (no lighting) with SIM 21-1. * Default: 50K * Clear: SIM 20-1	
	Machine	Not stop	

*1: Installation of a new toner cartridge allows to display the remaining quantity.

3. Note for replacement of consumable parts

A. Toner cartridge

When a waste toner cartridge is removed from the machine, it must be put in a polyethylene bag to avoid scattering of toner.

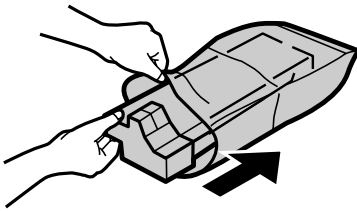

B. DV cartridge

Do not shake or put up the developer cartridge. Otherwise developer may scatter.

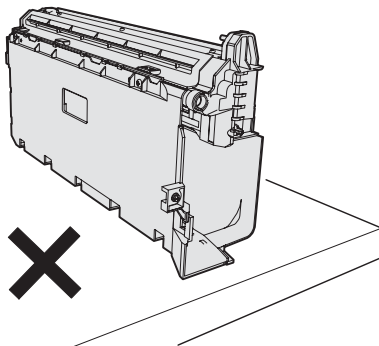

C. DV seal attachment procedure

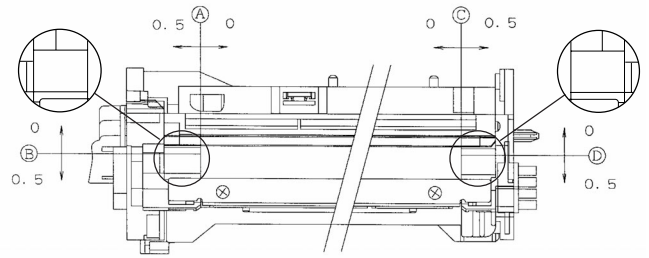

- 1) When attaching the DV side Mylar, check the position shown in the figure below and attach it properly.

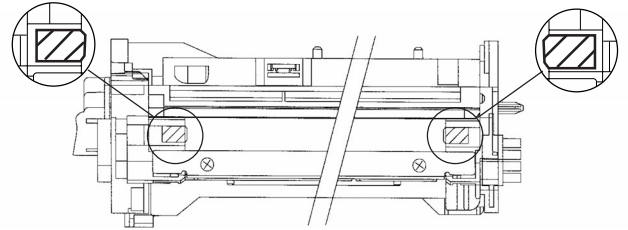

- 2) When attaching the DV side sheet, check the position shown in the figure below and attach it properly. (First of all, attach the DV side Mylar.)

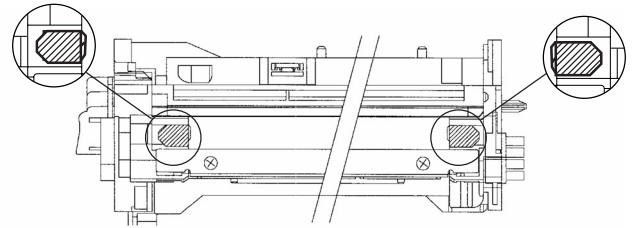

- * Be sure to attach the DV side sheet so that the notch is on the outside.

[13] ELECTRICAL SECTION

1. Block diagram

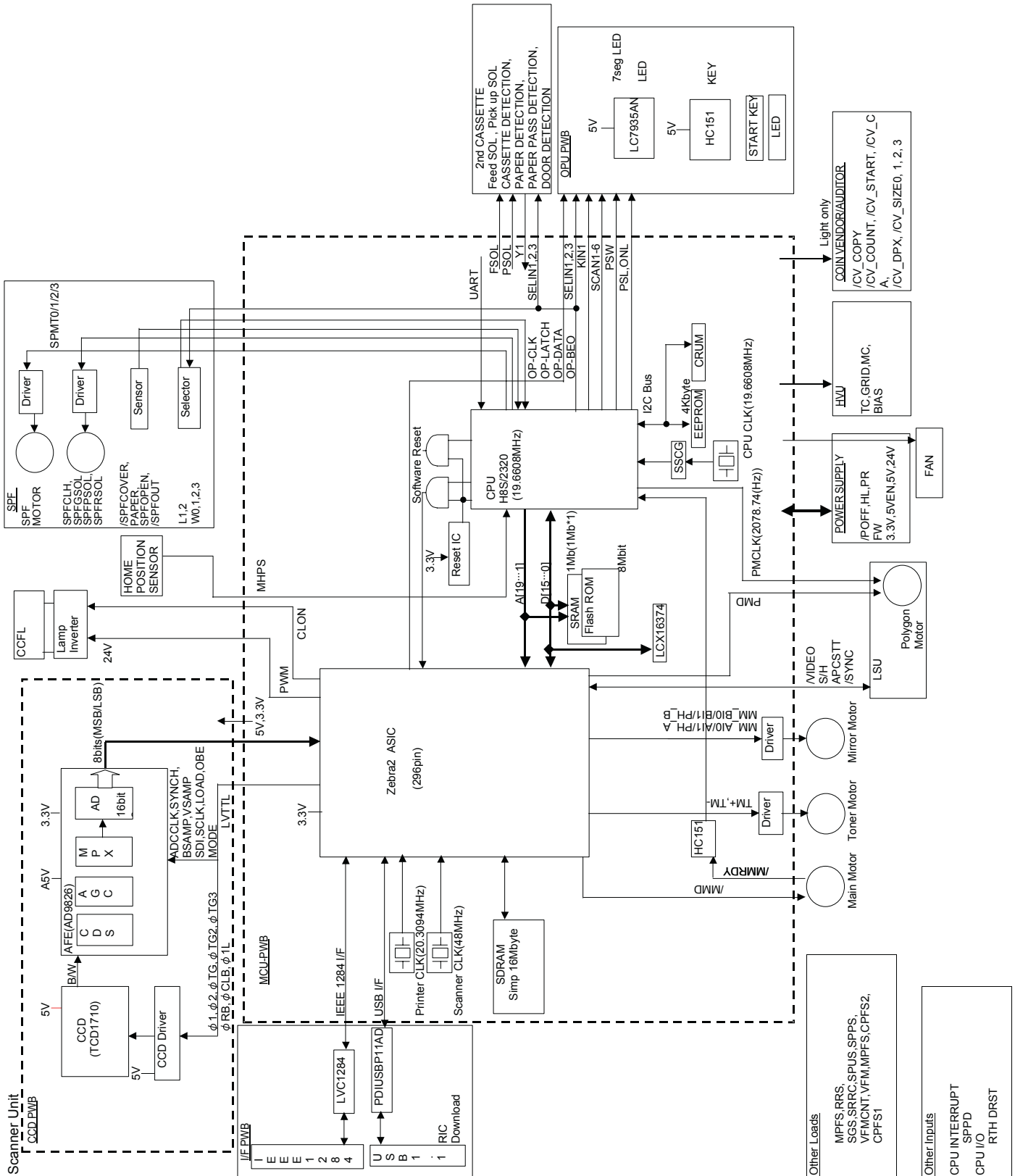

LEAD-FREE SOLDER

The PWB's of this model employs lead-free solder. The "LF" marks indicated on the PWB's and the Service Manual mean "Lead-Free" solder. The alphabet following the LF mark shows the kind of lead-free solder.

Example:

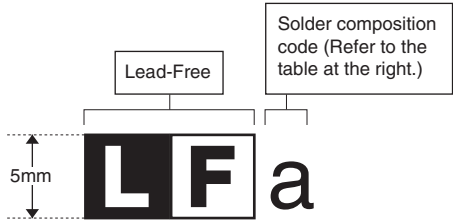

<Solder composition code of lead-free solder>

Solder composition	Solder composition code
Sn-Ag-Cu	a
Sn-Ag-Bi Sn-Ag-Bi-Cu	b
Sn-Zn-Bi	z
Sn-In-Ag-Bi	i
Sn-Cu-Ni	n
Sn-Ag-Sb	s
Bi-Sn-Ag-P Bi-Sn-Ag	p

(1) NOTE FOR THE USE OF LEAD-FREE SOLDER THREAD

When repairing a lead-free solder PWB, use lead-free solder thread.

Never use conventional lead solder thread, which may cause a breakdown or an accident.

Since the melting point of lead-free solder thread is about 40°C higher than that of conventional lead solder thread, the use of the exclusive-use soldering iron is recommendable.

(2) NOTE FOR SOLDERING WORK

Since the melting point of lead-free solder is about 220°C, which is about 40°C higher than that of conventional lead solder, and its soldering capacity is inferior to conventional one, it is apt to keep the soldering iron in contact with the PWB for longer time. This may cause land separation or may exceed the heat-resistive temperature of components. Use enough care to separate the soldering iron from the PWB when completion of soldering is confirmed.

Since lead-free solder includes a greater quantity of tin, the iron tip may corrode easily. Turn ON/OFF the soldering iron power frequently.

If different-kind solder remains on the soldering iron tip, it is melted together with lead-free solder. To avoid this, clean the soldering iron tip after completion of soldering work.

If the soldering iron tip is discolored black during soldering work, clean and file the tip with steel wool or a fine filer.

SHARP

COPYRIGHT © 2003 BY SHARP CORPORATION

All rights reserved.

Printed in Japan.

No part of this publication may be reproduced,
stored in a retrieval system, or transmitted,
in any form or by any means,
electronic, mechanical, photocopying, recording, or otherwise,
without prior written permission of the publisher.

Trademark acknowledgments

Windows and Windows NT are trademarks of Microsoft Corporation in the U.S.A. and other countries.

IBM and PC/AT are trademarks of International Business Machines Corporation.

PCL is a trademark of Hewlett-Packard Company.

Pentium is a registered trademark of Intel Corporation.

All other trademarks and copyrights are the property of their respective owners.

SHARP CORPORATION
Digital Document System Group
Products Quality Assurance Department
Yamatokoriyama, Nara 639-1186, Japan

2003 Dec. Printed in Japan (N)